

1	2	3	4	5	6
NUM.	COD.	QNT.			
1	CONSMB040-SAN-AC-TOR-ZN	1			
2	ANCSMB040-SAN-AC-LAS-ZN-RE	1			
3	MOLSMB040-SAN-AA-LAS	1			
4	FLASMB040-SAN-AC-LAS-ZN-RE	1			
5	DISSMB040-SAN-IX-LAS	1			
6	MOZSMB040-SAN-AC-TOR	1			
7	DITSMB040-SAN-OT-TOR-RE	3			
8	VITS3x35	3			
9	VITSC2.5x10	2			
10	VITC2X4	3			
11	GRA2.5X3	2			

BRAKE SPECS.	
Nominal brake static torque	0,7Nm
Nominal voltage	24Vdc
Insulation class	F
Max. speed	6000rpm
Max. Noise	40dBa
Armature plate pull-in time	≤ 0,032
Armature plate release time	≤ 0,025
Cables section	2x 20 AWG
Fixing screws torque	1.13Nm

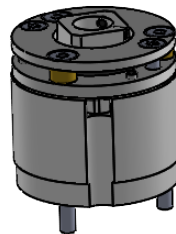
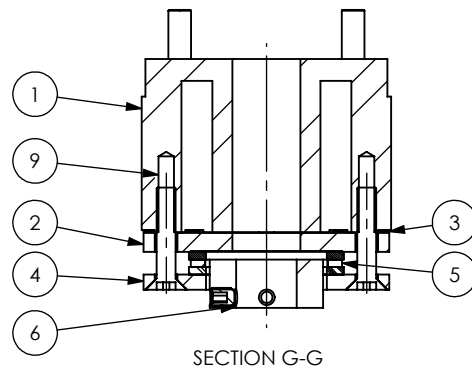
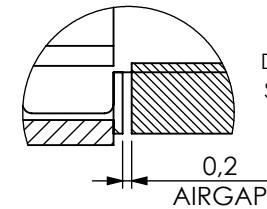
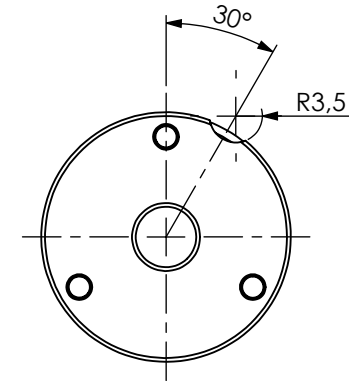
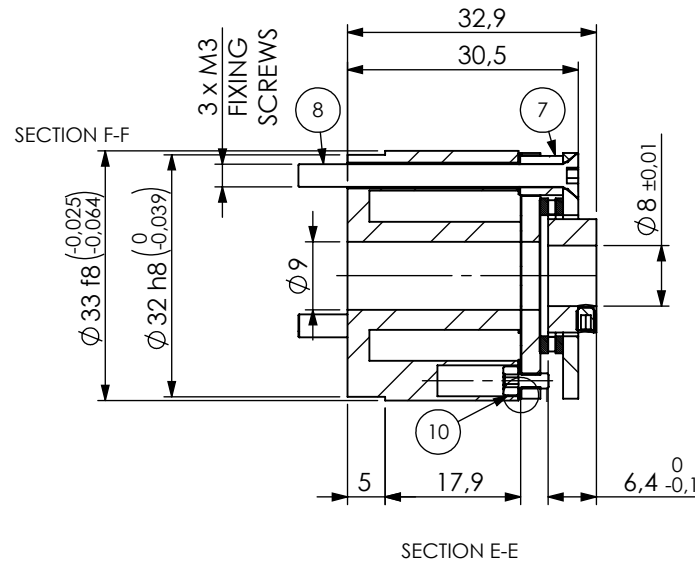
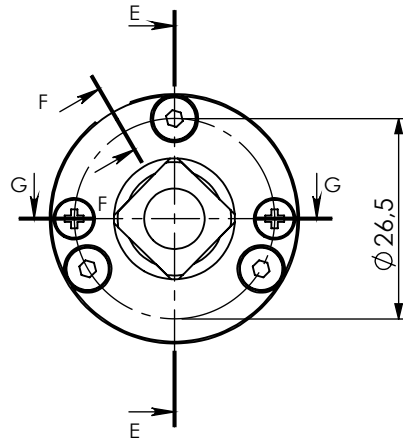
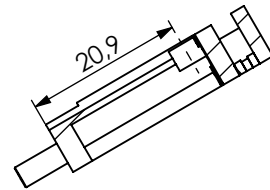

CHEMICAL TREATMENT: TERMICAL TREATMENT:	This drawing replaces all previous revisions REV.: 17/05/2023 09:56:01						
GENERAL TOLERANCES ACCORDING TO: UNI -EN 22768-cK	GENERAL Ra: 6.3 / 3.2 / 1.6 / 0.8 <small>RETIFICA</small>						
CHARACTERISTICS DEFINITION:	NON DIMENSIONED EDGES: 0,2x45°						
<table border="1"> <thead> <tr> <th>SYMBOL</th> <th>DEFINITION</th> </tr> </thead> <tbody> <tr> <td></td> <td>CRITICAL DIMENSION QUALITY CONTROL BALOON</td> </tr> <tr> <td></td> <td>STANDARD DIMENSION QUALITY CONTROL BALOON</td> </tr> </tbody> </table>	SYMBOL	DEFINITION		CRITICAL DIMENSION QUALITY CONTROL BALOON		STANDARD DIMENSION QUALITY CONTROL BALOON	DRAWING NAME: <h2>SMB040 Brake group</h2>
SYMBOL	DEFINITION						
	CRITICAL DIMENSION QUALITY CONTROL BALOON						
	STANDARD DIMENSION QUALITY CONTROL BALOON						
MATERIAL:	Temporiti srl Via Mattei, 8 - 20010 Mesero (MI) tel. 02 9787331 - fax 02 97289574						
PESO: g	DRAWN BY: FF CHECKED BY: / SCALE: 1:2 PAGE 1 di 1						