

BRAKE SPECS.	
Nominal brake static torque	72Nm
Nominal voltage	24Vdc
Nominal wattage	62,5W
Nominal current	2,6A
Insulation class	F
Max. speed	5000rpm
Coil protection	IP54

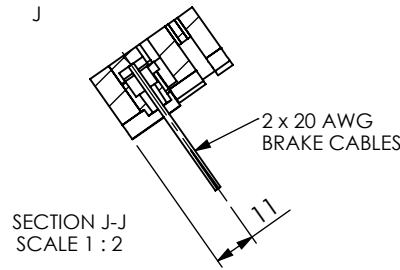
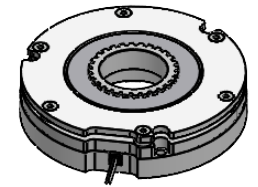
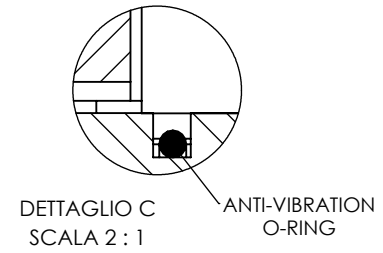
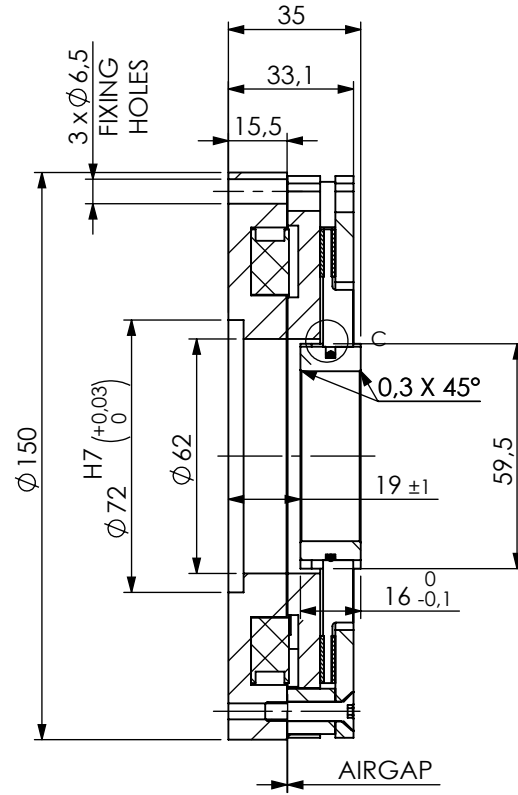
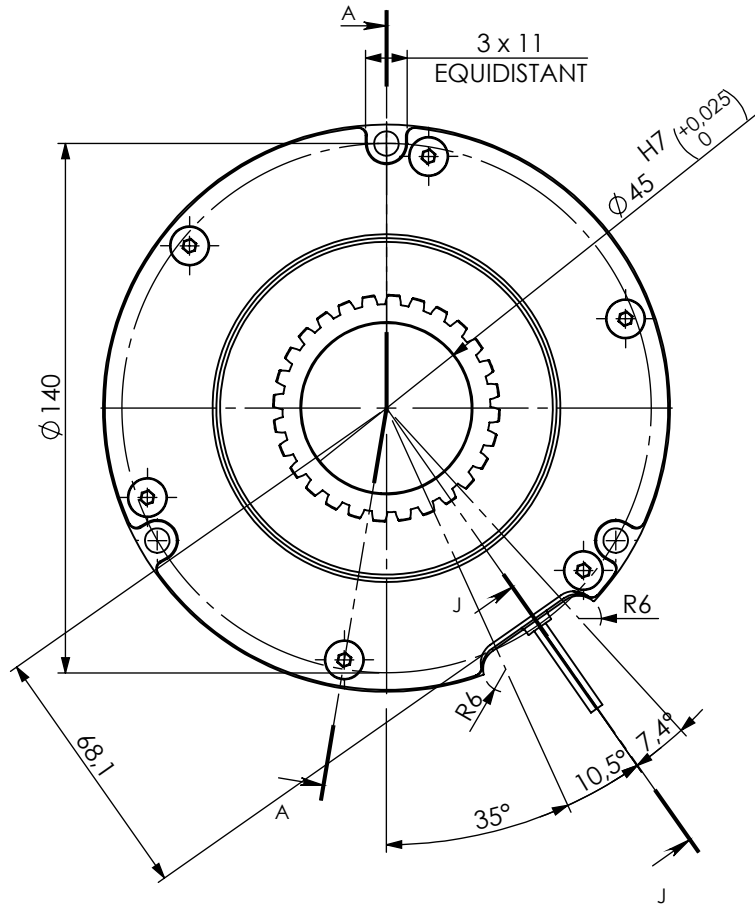

SECTION A-A
SCALE 1 : 2

<p>CHEMICAL TREATMENT:</p>	<p>TERMICAL TREATMENT:</p>	<p>This drawing replaces all previous revisions</p>	<p>REV.: 05/04/2023 16:27:43</p>						
<p>CHARACTERISTICS DEFINITION:</p> <table border="1"> <thead> <tr> <th>SYMBOL</th> <th>DEFINITION</th> </tr> </thead> <tbody> <tr> <td>$\triangle n$</td> <td>CRITICAL DIMENSION QUALITY CONTROL BALOON</td> </tr> <tr> <td>$\circ n$</td> <td>STANDARD DIMENSION QUALITY CONTROL BALOON</td> </tr> </tbody> </table>		SYMBOL	DEFINITION	$\triangle n$	CRITICAL DIMENSION QUALITY CONTROL BALOON	$\circ n$	STANDARD DIMENSION QUALITY CONTROL BALOON	<p>GENERAL TOLERANCES ACCORDING TO: UNI -EN 22768-cK</p>	<p>GENERAL Ra: 6.3 / 3.2 / 1.6 / 0.8 <small>RETTIFICA</small></p>
SYMBOL	DEFINITION								
$\triangle n$	CRITICAL DIMENSION QUALITY CONTROL BALOON								
$\circ n$	STANDARD DIMENSION QUALITY CONTROL BALOON								
<p>MATERIAL:</p>		<p>NON DIMENSIONED EDGES: 0,2x45°</p>	<p>DRAWING NAME:</p>						
<p>PESO:</p>		<p>DRAWN BY: FF</p>	<p>CHECKED BY: GO</p>						
<p>SCALE: 1:2</p>		<p>SCALE: 1:2</p>							
<p>Temporiti srl Via Mattei, 8 - 20010 Mesero (MI) tel. 02 9787331 - fax 02 97289574</p>		<p>A4</p>							
<p>PAGE 1 di 1</p>		<p>PAGE 1 di 1</p>							